

The Syntax of Chalcatongo Mixtec: Preverbal and Postverbal¹

Monica Macaulay
University of Wisconsin-Madison

1. Introduction

This paper has three goals: the first is to provide the reader with a tour of the basic facts of Chalcatongo Mixtec syntax, the second is to discuss some claimed correlates of VSO word order in the light of the Chalcatongo Mixtec data, and the third is to provide some comments on analyses of VSO word order with respect to the data presented.

Before beginning, a bit of background on the language is in order, since it may not be familiar to the reader: Mixtec is one of the three languages of the Mixtecan branch of the Otomanguan family. The dialect discussed here is spoken in the village of Chalcatongo, located in the highlands of the state of Oaxaca. But in fact, what we call ‘Mixtec’ is actually a group of related—but distinct—languages. Nonetheless, Mixtecanists traditionally use the term ‘dialect’ to describe the varieties of Mixtec because the region consists of complex dialect continua rather than discrete languages, and it is almost impossible to say where one ‘language’ stops and the next begins. Suárez (1983:18) estimates that there are approximately 29 distinct languages within what we call ‘Mixtec’, but acknowledges that any method of testing mutual intelligibility has its shortcomings. The upshot of all this is that we quite frankly do not—and cannot—know how many Mixtec languages there are.

As an example of the kinds of phonological differences found even between geographically close dialects, Table 1 provides a comparison of forms from Chalcatongo Mixtec with their cognates in San Miguel el Grande Mixtec, spoken in a village only eight kilometers away:²

¹ Many thanks to Vivian Lin, Marianne Milligan, Rebecca Shields, and Joe Salmons for their comments and help with this paper. Naturally all infelicities are my responsibility.

² Abbreviations which are used in this paper: 1, 2, 3 – 1st, 2nd, 3rd person; ADD – additive; CAUS – causative; CFACT – counterfactual; COMP – complementizer; COND – conditional; COP – copula; CP – completive; EMPH – emphatic; F – feminine; FOC – focus; HORT – hortative; INCHO – inchoative; LOC – locative; MN – masculine; NEG – negative; NOM – nominalizer; OPT – optative; P – potential; PL – plural; POL – polite; R – realis; REP – repetitive; TEMP – temporal; *vi* – intransitive verb. ‘=’ marks a clitic boundary.

	CHALCATONGO	SAN MIGUEL
‘sky’	andíú	andíví
‘blanket’	tíkàì, tikèi, tékei	tikàčí
‘there’	wáã	yúã
‘corncob’	níñí	niñi
‘comal’	šiò, šòð	xiò
‘slippery’	líʔu	líʔví
‘work’ (<i>vi</i>)	sátĩũ	sátĩũ

Table 1: Comparison of Forms in Two Closely-Related Dialects of Mixtec (Salmons 1992)

The reason for providing Table 1 at this point is simply to highlight the fact that the dialects of Mixtec—even those which are mutually intelligible—can differ significantly. It is true that all of the dialects are VSO, but as shown below, they do differ to some extent in how they instantiate VSO syntax. Because of this, my remarks here should be taken as illustrative only of the Chalcatongo dialect unless otherwise noted.

I begin in the next section by discussing correlates of VSO word order in Chalcatongo Mixtec (“CM” in what follows), then turn in §3 to CM clausal syntax, where I discuss non-basic word orders; the distribution of pronominal clitics, lexical DPs, and full pronouns; and preverbal and postverbal subjects. In the latter two subsections, I consider the difference between topic and focus phrases, and provide a basic structure for the CM clause. §4 concludes the paper.

2. Correlates of VSO Word Order

We start by noting that basic word order in Chalcatongo Mixtec is VSO, as illustrated in (1) and (2):

- (1) TRANSITIVE VERB: VSO
 nì-naa inì čáá ndoʔò
 CP-lose insides man basket
 ‘The man forgot his basket’
- (2) INTRANSITIVE VERB: VS
 ni-na-ičì saʔma=ró
 CP-REP-be.dry clothes=2
 ‘Your clothes have dried’

(1) shows a transitive verb, ‘forget’, followed by a subject and then an object; note that in CM ‘forget’ is a complex verb composed of a verb (‘lose’) plus a body part term (‘insides’). In (2) an intransitive verb, ‘to be dry’ is followed by its subject.³

2.1. Greenbergian Correlates

CM shows most of the expected Greenbergian correlates of VSO order, as shown in (3)-(6). That is, CM has prepositions (3), nouns precede modifying adjectives (4), the genitive follows the head in possessive constructions (5), and interrogatives are initial in WH-questions (6).

(3) PREPOSITIONS

- a. kù kaka=žó_{PP}[ondé San Miguel]
 be.able walk=1PL up.to *San Miguel*
 ‘We can walk to San Miguel’
- b. ni-sá?a=rí ỹř šìò_{PP}[xakúu sesí?í=rì]
 CP-make=1 one skirt for daughter=1
 ‘I made a skirt for my daughter’

(4) NOUN-ADJECTIVE

- a. lagúna kǎ?nũ
laguna big
 ‘big lake’
- b. sũ?nũ tũũ
 shirt black
 ‘black shirt’

(5) NOUN-GENITIVE

- a. kačíní peðrú ‘Pedro’s hat’
 hat *Pedro*
- b. ndùa ndíkandí ‘the sun’s rays’
 ray sun

(6) INTERROGATIVE INITIAL IN WH-QUESTIONS

- a. ndéu ní-ka-žaà táa=ní
 where CP-PL-live parent=2POL
 ‘Where did your parents live?’

³ Body part terms are multifunctional in CM (this is actually an areal feature); they not only refer to actual body parts, but they also form complex verbs like the one in (1), and serve to express location. Further examples occur below.

- b. šínaxaʔa xakú=ro
 why laugh=2
 ‘Why are you laughing?’

In addition, as (7) shows, the alternate order SVO is relatively common (I return to this topic below):⁴

(7) SVO ORDER

- ñáʒĩũ wǎǎ́ ni-ka-xáʔa ñũ̀̀
 people that CP-PL-pass.by town
 ‘Those people went to the town’

Greenberg also makes various observations about yes/no questions in VSO languages, and this issue is an interesting one when we look across the Mixtec dialects. Chalcatongo Mixtec simply makes no distinction whatsoever between statements and yes/no questions, relying entirely on context to disambiguate. But an entire range of possibilities are found in other dialects, as shown in Table 2:⁵

STRATEGY	DIALECT	FORM
S-initial particle	Alacatlazala	án
	Ayutla	ñáá/áán
	Jamiltepec	atu
	Ocotepec	á
	Silacayoapan	á
S-final particle	Diuxi-Tilantongo	á
	Yosondúa	nú
2 nd position particle	Coatzospan	ndu
Tone change	Ayutla	—
No overt marking	Chalcatongo	—
	San Miguel	—

Table 2: Yes-No Question Formation Across Mixtec Dialects

As the table shows, questions can be formed with a sentence-initial particle, a sentence-final particle, a second position particle, a change in tone, or with no overt marking at all (as in CM). What is relevant here is first Greenberg’s universal #9: “With well more than chance frequency, when question particles or affixes are specified in position by reference to the sentence as a whole, if initial, such elements are found in prepositional languages, and, if final, in

⁴ Note that the verb in this sentence is transitive, despite its translation into English.

⁵ Data taken from Zylstra (1991), Hills (1990), Johnson (1988), Alexander (1988), Shields (1988), Kuiper and Oram (1991), Farris (1992), Small (1990), and Pike (1944).

postpositional” (1963:64), and his universal #10, which states that question particles, “when specified in position by reference to a particular word in the sentence, almost always follow that word,” and further, that “Such particles do not occur in languages with dominant order VSO” (1963:64).

These are clearly contradicted—in a variety of ways—by the data from a number of the Mixtec dialects. First, the Mixtec dialects are prepositional, yet at least two have sentence-final question particles. Second, if we can assume that specifying the position of the particle with reference to “a particular word” includes second position, then we have a case (in Coatzospan Mixtec) in which such a particle does occur in a VSO language.

I think this is an interesting and important point because it highlights the potential pitfalls of typological surveys—even a sample which was carefully balanced geographically and otherwise would presumably only include one Mixtec dialect (if it included any), and if it was the wrong one, the wrong generalization could emerge.

2.2. Other Correlates of VSO

At this point I turn to additional correlates of VSO order which have been noted by other authors: lack of non-finite verb forms, absence of a copula, and lack of a lexical verb ‘have’.

2.2.1. Lack of Non-Finite Verb Forms (Myhill 1985)

Myhill (1985) notes that VSO languages often lack non-finite verb forms. This is true of CM, as the examples in (8) illustrate:

(8) LACK OF NON-FINITE VERB FORMS

- (a) ni-kexáʔá=Ø xíçi=Ø
 CP-start=3 bathe.R=3
 ‘He started to bathe’
- (b) kuní=rí kée=rí
 want=1 eat.P=1
 ‘I want to eat something’
- (c) x^wã nì-kunì=Ø xa=nà-šuk^wĩĩ=rí
 Juan CP-want=3 COMP=REP-turn=1
 ‘Juan wanted me to go back home’

In the first two of these examples the verbs in the subordinate clauses are marked as “R” and “P.” Almost all Mixtec verbs have (at least) two aspectual stems, the realis (“R”) and the potential (“P”). These may differ segmentally, by tone, or segmentally *and* by tone. Potential aspect is used to present events as possible, probable, or potential, while realis is used to describe events which are underway at the time of the speech event, are habitual, or have already been

finished at the time of speaking. There are, however, no infinitives or participles in Mixtec. In (8a) we see a realis stem used in a control construction, and in (8b) we see a potential stem used. (8c) shows what translates as an ECM construction in English; the Mixtec, though, is closer to ‘Juan wanted that I should go home’ or something along those lines. Thus CM does fit Myhill’s observation up to this point.

But Myhill mentions a secondary correlate of this tendency: “Many verb-initial languages freely use nominalizations to represent presuppositional Verbal Concepts where SV languages would use a finite or non-finite verb form” (1985:182). This raises an interesting issue in CM: the primary complementizer in the language is homophonous with its only nominalizing prefix, making subordinate clauses look like they might be nominalized. This complementizer, xa-, appears in (8c) (where it is underlined); the nominalizer xa- is illustrated in (9) and (10):

- (9) (a) keè xá-ndáa
 speak NOM-true
 ‘Speak the truth’
- (b) saʔma=rí kú xa-k^waʔá
 clothes=1 COP NOM-red
 ‘My clothes are the red ones’
- (10) (a) xa-bĩšĩ ‘fruit’
 NOM-sweet
- (b) xa-lúlí ‘child, boy’
 NOM-small

In (9) we find examples of productive nominalizations with xa-; in (10) we find examples which have conventionalized (although fairly transparent) meanings.

It is clear that these two elements (the complementizer and the nominalizer) are diachronically related, but I have argued elsewhere (Macaulay 1996) that they are synchronically distinct. Briefly, we can note first that they have different distributions: one is a phrasal affix (or clitic), and the other is a derivational affix. Furthermore, Mixtec subordinate clauses show no morphological indication of being nominalized (so for example, person marking appears on the verb within the clause, rather than at the end, as we would expect if the whole clause were a nominal). Thus, they have to be differentiated in a synchronic account of Chalcatongo Mixtec. Nonetheless, the diachronic relationship and Myhill’s generalization are intriguing.

2.2.2. Lack of a Copula (Carnie and Guilfoyle 2000; others)

Moving on to our next correlate of VSO order, Carnie and Guilfoyle (2000) (citing Carnie (1995))—and others—have observed that VSO languages tend to lack a copula in sentences with non-verbal predicates. CM does have a copula (in fact it has several elements that seem to function as copulas), but adjectival predicates can also be expressed without one.

We begin with nominal predicates in CM, which require a copula, kúu. Consider (11):

- (11) (a) ruʔu kúu=rí íí hàsiʔi
 I COP=1 one woman
 ‘I am a woman’
- (b) máá kúu žii=ri
 EMPH COP husband=1
 ‘He is my husband’

These sentences would be ungrammatical without kúu. However, as mentioned above, the copula can be omitted with adjectival predicates. Consider (12) and (13):

- (12) (a) x^wǎ kaa lúlí
 Juan COP small
 ‘Juan is small/short’
- (b) ndežu káa žaʔu
 food COP expensive
 ‘The food is expensive’
- (13) (a) čáʔǎ xalúlí
 dirty boy
 ‘The boy is dirty’
- (b) níʔní nduča
 hot water
 ‘The water is hot’

As (12) shows, the copula takes the form kaa with adjectives, rather than the kúu seen with nouns. (13) provides two examples with bare adjectival predicates.⁶ There is one unanswered question here, though: what is the difference between the verbless sentences with adjectival predicates and the ones with a copula? Note that in (13a) and (b) the adjectival predicate is initial. A possible explanation for the difference might therefore be that the copula appears only when the subject is focused. However, occasionally subject-initial sentences with adjectival predicates are also verbless, as in (14):

- (14) nduča žáʔa biši šǎǎ
 water this warm very
 ‘This water is very warm’

Some other dialects of Mixtec show the same pattern—that is, adjectival predicates with and without a verb that takes the form kaa (with varying tones depending on dialect). In several of

⁶ I should point out here that there are two things that distinguish adjectives from verbs in CM: first, only adjectives have the option of occurring with the copula kaa, and second, adjectives cannot occur with verbal inflection such as the plural marker or completive aspect. So it is clear that these forms *are* adjectives, not verbs.

the dialects (for example, Jamiltepec (Johnson 1988), Ocotepec (Alexander 1988), and Diuxi-Tilantongo (Kuiper and Oram 1991)), this verb is translated as ‘appear’ or ‘seem’, which would explain its optional presence. But this distinction did not emerge in my work on CM, and so I leave this an open and unfortunately unanswered question for now.

The Mixtec dialects, then, only partially conform to the observation that VSO languages tend to lack a copula—adjectival predicates can be expressed without one, but nominal predicates require one.

2.2.3. Lack of a Verb ‘Have’ (Freeze and Georgopolous 2000)

The third correlate of VSO order to be discussed is brought up by Freeze (1992) and Freeze and Georgopolous (2000), who claim that “... in contrast to SVO and SOV languages, there are no ‘have’ lexicalizations in the possessive sentences of verb initial languages” (2000:167). CM is a direct counterexample to this claim, since it has a very robust verb ‘have’ in possessive constructions.

Freeze and Georgopolous’s claim, more specifically, is that instead of using a verb ‘have’ for possessive sentences, verb-initial languages make use of an existential construction like that illustrated in (15) for Yucatec. In this example, the possessor subject (‘my father’) is a locative argument, the possessed argument (‘a horse’) is a theme, and the predicate is a locative copula.

- (15) YUCATEC [Freeze and Georgopolous 2000:167, example (4b)]
 yaan huntul ciimin ti? in-paapa
 COP.LOC one horse P my-father
 ‘My father has a/one horse’

But CM has precisely the verb Freeze and Georgopolous say it should not have, as shown in (16):⁷

- (16) (a) ñába?a=Ø kwã?ã šú?ũ
 have=3 much money
 ‘He’s going to have a lot of money’
 (b) žubà?à=rí ħħ dōzená staa
 have=1 one *dozena* tortilla
 ‘I have a dozen tortillas’

Freeze and Georgopolous actually discuss three locative constructions (predicate locatives, existentials, and possessives), claiming that the data provide evidence for different underlying word orders and derivational histories for the different word order types, contra much current work in syntax. This CM counterexample undermines at least part of their argument.

⁷ The two forms for ‘have’ given here reflect a minor dialect variation among CM speakers.

3. CM Clausal Syntax

At this point I turn to two related issues in the syntax of CM: first, the types of non-basic word orders found in the language, and second, the use of pronominal clitics and their cooccurrence with coreferential DPs and full pronouns. These are both discussed with an eye to the evidence the data provide concerning the most appropriate analysis of the derivation of CM word order.

3.1. Non-basic Word Orders

In example (7), above, we saw that SVO is a common alternative word order in CM. Two more examples of subject-initial order are provided in (17):⁸

(17) INITIAL SUBJECT

(a) spexó táʔu
espejo break(*vi*)
 ‘The mirror breaks/is broken’

(b) Pedro xínú žáčí šãã
Pedro run fast very
 ‘Pedro runs very fast’

In addition to subjects, a wide range of arguments and non-arguments can appear before the verb in CM. Consider first (18)-(19):

(18) INITIAL OBLIQUE

(a) čìì žuù wãã žáá íí kòò
 stomach rock that live one snake
 ‘Under that rock lives a snake’

(b) nù žúkú wãã žáá íí báʔù
 face mountain that live one coyote
 ‘In those mountains lives a coyote’

(19) INITIAL OBJECT

(a) tutù wãã nì-xàʔža peďrú
 paper that CP-cut *Pedro*
 ‘Pedro cut that (piece of) paper’

(b) statilá nì-saʔa miguel
 bread CP-make *Miguel*
 ‘Miguel made the bread’

⁸ Carnie (1995:38, n. 9) points out that the notion of SVO as a ‘common alternative word order’ might need to be defined more carefully (especially for languages like Modern Irish and Arabic), but in CM the structure is quite straightforward, as shown in these examples.

(18) provides two examples of oblique-initial sentences ('under that rock' and 'in those mountains'—both using body part terms in the way mentioned in note 3), and (19) provides two examples of object-initial sentences. Initial subjects and initial obliques are fairly common; initial objects are fairly rare, but they can and do occur.

The initial constituent does not actually have to be an argument of the verb, though. (20) shows initial non-argument DPs, and (21) shows initial adverbials:

(20) INITIAL NON-ARGUMENT DP

- (a) *čàà tú=žóó seʔe*
 man NEG=exist child
 'That man has no children' (lit. 'As for that man, children do not exist')
- (b) *maría ni-teʔnde saʔma=Ø*
María CP-rip(vi) dress=3
 'María ripped her dress' (lit. 'As for María, her dress ripped')

(21) INITIAL ADVERBIAL

- (a) *nù žoð nù žo kīʔĩ=rí nužáʔu*
 face month face month go=1 market
 'Every month I will go to the market'
- (b) *wáã ni-ka-žée=Ø staa*
 there CP-PL-eat=3 tortilla
 'There, they ate'

There can also be more than one preverbal constituent, as in (22)-(23):

(22) (a) INITIAL DP + ADVERBIAL

ñáni=rí šã káʔã
 brother=1 much talk
 'My brother talks a lot/too much'

(b) INITIAL ADVERBIAL + DP

iku maría ni-xiʔi
 yesterday *María* CP-die
 'Yesterday María died'

(23) TWO PREVERBAL CONSTITUENTS

- (a) *kaxá wáã tènana ñúʔũ*
caja the tomato contain
 'The box contains tomatoes'
- (b) *burrú=ró wáã nužáʔu xíndee*
burro=2 that plaza be.in
 'Your burro is in the plaza'

As (22) shows, a DP and an adverbial can cooccur before the verb in either order (subject–adverb in (a) and adverb–subject in (b)). (23) shows two very unusual examples of SOV word order, and I return to these examples at the end of the paper.

3.2. Distribution of Pronominal Clitics, Lexical DPs, and Full Pronouns

CM has an extensive set of pronominal clitics. Table 3 provides the complete list, along with the corresponding free forms.

PERS	GENDER	CLITIC	FREE	
			FORM	MEANING
1	FAMILIAR	=rí	rùʔù	
	POLITE	=na	naʔa	
	INCLUSIVE (PL)	=žó	žóʔó	
2	FAMILIAR	=ro	roʔo	
	POLITE	=ní	níʔí	
3	MASCULINE	=ðe	čàà	‘man’
	FEMININE	=ñá	ñáʔã	‘woman’
	POLITE: OLDER	=to	toʔò	‘Señor’
	ANIMAL	=ti	kíti	‘animal’
	SUPERNATURAL	=ža	íʔa, íža	‘God’
	YOUNGER, DECEASED, etc.	=ži	(žii	‘man’)
	UNMARKED	=Ø		

**Table 3: Chalcatongo Mixtec
Pronominal Clitics**

These clitics appear on DPs, to mark possession; they attach to prepositions to mark the object of the preposition; and they appear on predicates, to mark subject. As the table shows, the first and second person clitics correspond to full pronouns, while the third person pronominal clitics correspond to nouns with generic reference, rather than to pronouns. In the terminology of Zwicky (1977), these clitics are ‘special clitics’—that is, they appear in different syntactic environments from those of the full forms. In addition, the distributional restrictions on the full first and second person pronouns are different from those on the full nonpronominal nouns.

Tables 4a and b provide examples of the positions of subject DPs, subject pronouns, and subject clitics in CM.

EXAMPLE	PATTERN
(24) xínũ ñǎ?ǎ wǎ run woman that 'That woman is running'	V – lexical DP
(25) *xínũ=ñǎ ñǎ?ǎ wǎ run=3F woman that (‘That woman is running’)	*V = clitic – lexical DP
(26) xínũ=ñǎ run=3F 'She's running'	V = clitic
(27) *nì-žee rù?ù CP-eat I (‘I ate’)	* V – pronoun

Table 4a: Distribution of Postverbal Subjects in CM

EXAMPLE	PATTERN
(28) ñǎ?ǎ wǎ xínũ woman that run 'That woman is running'	lexical DP – V
(29) rù?ù nì-žee I CP-eat 'I ate (it)'	pronoun – V
(30) ñǎ?ǎ wǎ xínũ=ñǎ woman that run=3F 'That woman is running'	lexical DP – V = clitic
(31) rù?ù nì-žee=rí I CP-eat=1 'As for me, I ate (it)'	pronoun – V = clitic

Table 4b: Distribution of Preverbal Subjects in CM

In Table 4a, (24)-(27) provide examples with postverbal subjects: (24) shows that the subject may be a lexical DP in postverbal position; (25) shows that a lexical DP in postverbal position may not be accompanied by a clitic; (26) shows that the clitic alone may appear as subject; and (27) shows that full pronouns may not appear postverbally.

We can summarize these facts as follows:

- A lexical DP or clitic may follow the verb,
- A clitic and lexical DP may not cooccur after the verb,
- A full pronoun may not occur after the verb.

In Table 4b, (28)-(31) provide examples with preverbal subjects: in (28) we have a full DP in preverbal position; in (29) there is a pronoun in preverbal position; (30) shows that a preverbal lexical DP may cooccur with a subject clitic; and (31) shows that a preverbal pronoun may likewise cooccur with a subject clitic.

This set of facts can be summarized as follows:

- A lexical DP or full pronoun may precede the verb, with no pronominal clitic,
- A lexical DP or full pronoun may precede the verb, cooccurring with a pronominal clitic.

Thus there are two facts to account for here: first, full pronouns may only appear preverbally, never postverbally, and second, when DPs or pronouns are preverbal, they may appear alone, or may be doubled by a pronominal enclitic.⁹

3.2.1. Postverbal Subjects

Returning now to the examples in Tables 4a and b, we begin with the postverbal set. (24)-(27) show complementarity between lexical DPs and clitic pronouns, indicating at an intuitive level that the clitics fill the subject argument position just as lexical DPs do. Lee (2000) provides evidence from adverb stranding that Zapotec clitics are in fact phrasal (as opposed to agreement heads which incorporate into the verb), and similar data are found in CM, as shown in (32):

- (32) (a) ni-žéé=rí staà
 CP-eat=1 tortilla
 ‘I ate’
- (b) ni-žéé šãã=rí staà
 CP-eat much=1 tortilla
 ‘I ate a lot/I ate excessively’

In (32a) we see a subject clitic attached the verb, followed by the object. In (32b), however, an adverb intervenes between the verb and the clitic. I take this as evidence that the verb raises out of VP past the adjoined AdvP—and I return to this topic shortly. However, at this point simply note that because the clitic occupies the subject position, there is no requirement that it raise with the verb (I also return below to the issue of whether the subject has independently

⁹ The distribution of free and clitic pronouns appears to vary quite a bit across the Mixtec dialects. For example, Johnson says that in Jamiltepec Mixtec, “both free and clitic forms occur in all syntactic environments, except that clitics do not occur in sentence-initial position” (1988:115). Although she is not explicit, looking through the text that she supplies, I found that full pronouns can indeed appear as postverbal subjects (whereas they cannot in Chalcatongo Mixtec). Alexander describes the free pronouns in Ocotepéc Mixtec as “show[ing] no distributional restrictions” (1988:264), again implying that full pronouns can appear postverbally. Furthermore, while most of the Ocotepéc clitics behave like the ones in Chalcatongo Mixtec, she says that “the second person respect form occurs alone as object of verb or in focus position” (Alexander 1988:264). Since these are normally *enclitics*, it is unclear what the pronoun would cliticize to in focus position; Alexander does not explain.

undergone raising). Thus the CM clitics are X^{\max} clitics, in the terminology of Halpern and Fontana (1994)—that is, maximal projections which provide the subject argument for the clause.

3.2.2. Preverbal Subjects: Focus vs. Topic

Next consider the preverbal data. In such cases, at least one element is found in a preverbal position. But here (unlike in the postverbal cases), we find both complementarity *and* clitic doubling. This might appear to lead us into a contradiction: it would seem that the complementarity between clitic pronouns on the one hand, and lexical DPs and full pronouns on the other, would indicate that the clitics fill the subject argument position. Yet the fact that there is also clitic doubling might be taken to indicate that the clitics are merely agreeing with a lexical DP or pronoun which serves as (preverbal) subject. The question we need to answer is this: which element is the subject in the doubling construction?

The evidence points very clearly towards the clitic serving as subject whether or not there is doubling with a DP or pronoun (in fact some authors would not even want to call this ‘doubling’, but I continue to do so for ease of reference). The first thing to note is that we find that the semantics are different between the undoubled constructions and the doubled ones. Sentences in which there is a single preverbal constituent and no clitic pronoun on the verb have *focus* semantics.¹⁰ Preverbal focus can either be simple new information focus, or can function as contrastive focus. (33a)-(b) illustrate:

- (33) (a) FOCUS
 rùʔù kúʔu
 I sick
 ‘I’m sick’ or ‘It’s me who’s sick’
- (b) CONTRASTIVE FOCUS
 rùʔù číʔi itù te máá=ðe číʔi ndučì tǔú
 I plant corn and EMPH=3MN plant bean black
 ‘I’m planting corn and/but *he*’s planting black beans’

One of the difficulties with these data is that since there is a zero third person clitic in CM, with third person examples it can be impossible to tell whether the initial DP or pronoun stands alone, or whether it is doubled by a non-overt clitic. I return to this issue below, but note that both examples in (33) have a first person subject and so the lack of the clitic is obvious.

¹⁰ It has to be acknowledged that focus (and topic) are notoriously difficult to define. For convenience, I follow Lambrecht’s (1994:213) definition of ‘focus’: “The semantic component of a pragmatically structured proposition whereby the assertion differs from the presupposition.” This contrasts with his definition of ‘topic’: “A referent is interpreted as the topic of a proposition if in a given situation the proposition is construed as being about this referent, i.e. as expressing information which is relevant to and which increases the addressee’s knowledge of this referent” (Lambrecht 1994:131).

Contrasting with the focus construction, sentences with both an initial DP or pronoun and a clitic on the verb are *topic* constructions (or what is also known as Left Dislocation).¹¹ Consider the examples in (34):

(34) TOPIC

- (a) roʔo tú=kúʔu=ro
 you NEG=sick=2
 ‘As for you, you’re not sick’
- (b) ruʔù žée=ka=rí
 I eat=ADD-1
 ‘As for me, I’m still eating’
- (c) ñáǰǰĩ wǎǎ ni-ka-xáʔa=Ø ñũũ
 people that CP-PL-pass.by=3 town
 Those people went to the town’ (‘As for those people, they went to the town’)

(34c) is repeated from (7), given earlier, but this time I have put the zero clitic in and suggested a more explicitly topic-like translation. This is an example of what was just mentioned: out of context the example would be ambiguous between a focus reading and a topic reading. That is, a sentence like this might contain a focused constituent with no pronominal clitic, or it might contain a topic with a zero clitic. Because the third person subject marker has no phonetic content, the topic might appear to be the unique bearer of the subject role, but in this particular example it is really the zero clitic which functions as the argument.

Occasionally the two possibilities (focus vs. topic) can be distinguished by intonation: in some cases there is a pause after a topic, but normally there is no pause after a focused element. (35) provides two such examples:

- (35) (a) x^{wǎ}, nì-kii=Ø žáʔa iku
 Juan CP-come=3 here yesterday
 ‘Did Juan come here yesterday?’ (‘As for Juan, did he come here yesterday?’)
- (b) x^{wǎ}, keè=Ø xa=čǐʔi=Ø nunì
 Juan say=3 COMP=plant=3 corn
 ‘As for Juan, they say he’s planting corn’

¹¹ Alexopoulou, Doron, and Heycock (2001) provide a typology of constructions involving left-peripheral constituents. They distinguish a number of such constructions, among them Left Dislocation (LD) and Clitic Left Dislocation (CLLD). What I have been referring to as the ‘topic’ in CM does not fit perfectly into either category. It has most of the characteristics of LD, except that the ‘resumptive’ pronoun is a clitic rather than a tonic pronoun, contrary to their claim about the pronoun in LD constructions. Other authors (for example Lambrecht 1994) do treat constructions with clitic (or otherwise unaccented) pronouns as Left Dislocation, though, and so I will continue to treat the CM topic in those terms.

Note that (35b) is an example of a sentence which not only has a pause after the topic but also shows that the topic can be coreferential with an argument of a subordinate clause, separated from it by the main clause.

However, most sentences with topics do not include a pause following the topic. Since there is no focus particle or any other element which distinguishes focus from topic, and since CM is a tone language—which generally rules out intonational cues—such utterances are generally just disambiguated by context.¹²

There is, however, one test for topic, to which we now turn.

3.2.3. Negation as a Test for Focus vs. Topic

CM has a bound negative marker tu= which corresponds to the full word túu, which means ‘no’. The bound form appears to the left of the verb (or other predicate), and also to the left of any preverbal adverb. Examples (36a) through (c) illustrate its use:

(36) CLAUSAL NEGATION

- (a) tu=ni-xížaa=ró
NEG=CP-be.located=2
‘You weren’t there’
- (b) tu=ká-ku si̯ iní=ro
NEG=PL-COP happy insides=2
‘You (PL) don’t feel happy’
- (c) tu=šãã sáʔa=Ø bĩxĩ
NEG=much make=3 cold
‘It’s less cold/It’s not so cold’

(36a) and (b) provide examples of preverbal negatives, and (36c) provides an example in which the negative marker precedes an adverb, indicating that tu= is a clitic.

Clauses with focused arguments, however, are not negated with tu=; instead, there is a special focus negator, as illustrated in (37):

(37) FOCUS NEGATION

- (a) niàsù čũũ li̯ ká-ku či ká-ku kóní lúlí
NEG.FOC chicken chick PL-COP but PL-COP turkey.hen small
‘They’re not *chicken* chicks, they’re turkey chicks’

¹² A few of the other Mixtec dialects (Ayutla, for example; Hills 1990:30) do have a topic marker, and it is described as being accompanied by a post-topic pause. Although most of the descriptions of Mixtec syntax which are available are frustratingly vague on the issues of topic and focus, it appears that the dialects that have a topic marker require a pronominal subject to occur on the verb, while they do not require one for focused subjects, parallel to what is found in CM.

- (b) niàsù ro?o kú?u
 NEG.FOC you sick
 ‘It’s not *you* who is sick’
- (c) *tu=ro?o kú?u
 NEG=you sick
 ‘It’s not *you* who is sick’

(37a) and (b) illustrate the focus negator niàsù. In (37c) we see that focus negation *cannot* be accomplished with the clausal negator tu=.

Finally, also note that topics appear outside of tu=, as in (38a) and (b):

- (38) (a) ndežu tú=ža?u=Ø
 food NEG=expensive=3
 ‘The food is not expensive’
- (b) sókó tú=šãã kũnú=Ø
 well NEG=much deep=3
 ‘The well is not very deep’

Having now explored a range of word order possibilities in CM, we turn to our last topic, which involves some comments on the structure of the CM clause. The special focus negator, niàsù, will be useful in determining the status of preverbal DPs in subordinate clauses.

3.3. Structure of the CM Clause

Parallel to the arguments that have been made by numerous authors for numerous other VSO languages, there is evidence in CM for the verb and its object comprising a constituent separate from the subject in underlying structure. A first—although admittedly weak—argument can be made from the single example with VOS order that I have found, shown in (39):

- (39) VOS ORDER
 čó?o či a-sá?a mísá sutù
 go.HORT because TEMP-make *misa* priest
 ‘Let’s go, because the priest is already starting the mass’

Since VOS is normally ruled out in CM, this example seems to show some sort of incorporation of the object into the verb. If we accept that the verb moves in derivation of CM clauses, in this case the verb and the object would have to move together, implying that they form a constituent. But since, as mentioned above, I have only found one such example, it has to be acknowledged as a fairly weak argument for the existence of a VP constituent.

Other arguments for VP which are parallel to the clefting and VP ellipsis facts in the Celtic languages (for example) seem to be lacking in CM, but various subject-object asymmetries do

hold. For example, as shown in (40) and (41), reflexives and reciprocals show the expected distributions:

(40) REFLEXIVES

- (a) ni-čisaʔí=ri máá=rí nuù=ðe
 CP-hide=1 self=1 face=3MN
 ‘I hid myself from him’
- (b) číkú xátãʔã máá=Ø
Francisco like self=3
 ‘Francisco likes himself’

(41) RECIPROCAL

- (a) ká-kani táʔã xináʔa
 PL-hit companion plural
 ‘They are hitting each other’
- (b) ni-ká-ku-manì nuù táʔã
 CP-PL-INCHO-love face companion
 ‘They love each other’

(40) shows that reflexives are formed with the word máá, ‘self’, marked with the appropriate pronominal clitic. Reciprocals also pattern as expected, although it should be noted that this is a marked strategy for expressing reciprocity. It is much more common to use a verb with inherent reciprocal meaning (e.g., a verb which means ‘to fight each other’), or to avoid the overt expression of reciprocity by making the subject plural (‘X and Y fight’), or to use a comitative (‘X fights with Y’). However, in the few cases where an overt reciprocal is expressed, the term táʔã is used, which in its non-reciprocal use means ‘companion’. At any rate, in both cases—that is, with reflexives and reciprocals—anaphors appear as expected in object position, where they are c-commanded by the subject, but cannot appear as subjects (as we might expect if the subject and object were sisters in a flat structure approach).¹³

Thus the evidence from CM indicates that it *does* have a constituent which contains just the verb and its object (which I will call V'), and that surface VSO word order is therefore derived by verb movement to some point to the left of the subject, as schematized in (42):

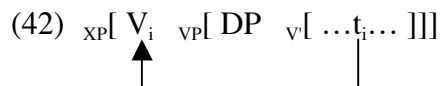

Carnie, Harley, and Pyatt (2000:41, 42) describe the two well-known verb-raising approaches to VSO word order, which they christen the “Raising to C Hypothesis” (“VSO order is derived

¹³ There is an interesting comment about reflexives in Mixtec in the introduction to Bradley and Hollenbach’s series on Mixtec syntax: “... most [languages in this family] have reflexive marking only optionally, and thus violate the binding conditions” (Bradley and Hollenbach 1988:6). Certainly, however, in Chalcatongo Mixtec reflexives appear consistently, and in the expected configurations.

via head movement of the verb to C^0) and the “Left Edge of Inflection Hypothesis” (“VSO order is derived via head movement of the verb to the highest inflectional head (AgrS/T/Infl). Arguments appear in surface positions lower than this head. There is no (overt) raising to C^0 ”).

CM is clearly of the latter type; that is, as in Modern Irish and many other VSO languages, the CM verb moves to the left edge of the highest inflectional head. Evidence for this comes from the fact that the verb can still appear clause-initially when the complementizer position is filled, as shown in (43a) and (b), and schematized (preliminarily) in (44):

- (43) (a) kuní=ri xa=ketá?ã=rí xĩ kú?u=rí
 want=1 COMP=meet=1 with sister=1
 ‘I want to find/meet up with my sister’
- (b) žú?ú=Ø xa=kúu táa=Ø
 be.afraid=3 COMP=die father=3
 ‘He is afraid that his father will die’

- (44) $_{CP} [C_{IP} [V_i \text{ }_{VP} [DP \text{ }_{v_i} [\dots t_i \dots]]]]]$
-

Having established this, accounting for the different types of preverbal constituent, as well as for the appearance and lack of appearance of the pronominal enclitics, turns out to be quite straightforward. Focused constituents (like the ones in (33)) get to preverbal position by movement. Some authors treat this as movement to a focus projection FP, while others (for example Black 2000) treats it as adjunction to IP. I leave the precise landing site aside for now; rather, my point here is simply that a movement analysis explains the complementary distribution of focused subjects and pronominal enclitics—focused subjects are generated in the same position as pronominal clitic subjects are, ruling out cooccurrence.

Recall that one of the things we needed to account for was the fact that full pronouns may only appear preverbally, never postverbally. This can be explained by simply assuming that the full pronouns carry a focus feature, and so have to be fronted.

Topics, on the other hand, are base generated, in a left-dislocation construction. I argued earlier that CM clitics are phrasal, or X^{\max} clitics; thus the clitic which cooccurs with a topic *is* the subject, and the topic is simply a coreferential doubling of that subject.

One piece of evidence in favor of base-generating topics in CM is the fact that topics do not have to be arguments of the clause in which they appear. In fact, we have already seen two examples of this—(45a) and (b) repeat the earlier (20a) and (b):

- (45) INITIAL NON-ARGUMENT DP
- (a) čàà tú=žóó se?e
 man NEG=exist child
 ‘That man has no children’ (lit. ‘As for that man, children do not exist’)

- (b) *maría ni-teʔnde saʔma*
María CP-rip(vi) dress
 ‘María ripped her dress’ (lit. ‘As for María, her dress ripped’)

In (45a) the subject of the existential is ‘child’, and ‘man’ simply gives us the relevant domain of (non-)existence. (45b) might look like a transitive clause with SVO word order, but crucially, the verb is *intransitive*, and its single argument is ‘dress’. If topics were derived by movement, it is difficult to see where non-argument topics would originate, since no position is licensed for them within the clause.

Earlier the complementizer–verb word order of subordinate clauses was mentioned as evidence in favor of the left-edge-of-inflection approach to verb movement in CM. However, it is also possible to have one (and only one) preverbal constituent in subordinate clauses, as shown in (46a) and (b) (in which the preverbal DP is bracketed):

- (46) (a) *ni-x̀ini=rí xa=[úu xa-siʔi lúli] ká-ndeʔe núu=rí*
 CP-know=1 COMP=[two NOM-feminine little] PL-look face=1
 ‘I knew that two girls were looking at me’
- (b) *kuní=ri xa=[xʷã] na-kí-noʔo béʔe*
 want=1 COMP=[*Juan*] MOOD-come-go.and.return house
 ‘I want Juan to go home (and come back)’

The preverbal constituent in such subordinate clauses is a focus, rather than a topic. One bit of evidence towards this conclusion comes from the focus negator described earlier. Consider (47):

- (47) *xʷã kéé=Ø xa=[niasu maría] tandaʔá xí péðrú*
*Juan say=3 COMP=[NEG.FOC *María*] marry with *Pedro**
 Juan says that it’s not *María* who is marrying Pedro

Recall that *niàsù* only appears with focused DPs, indicating that *María* is focused in (47).

A second—and conclusive—form of evidence comes from the fact that clitic doubling is never found with embedded preverbal constituents, as shown in (48):

- (48) (a) *kandíaa=rí xa=roʔo kuʔu*
 believe=1 COMP=you sick
 ‘I believe that you are sick’
- (b) *nú=rúʔù žúbaʔa šũʔú=nú . . .*
 COND=I have money=CFACT
 ‘If I had a lot of money . . .’

In (48a) there is no second person clitic doubling the pronoun roʔo, and in (48b) the first person clitic =rí fails to appear on the verb. If these were topics we would expect to see the clitic in addition to the pronoun in each case, but in fact it is ruled out.

It was mentioned above that there seems to be evidence for left-edge-of-inflection verb movement in CM. A second question considered by many in the analysis of VSO languages is whether the subject also raises. Obviously the null hypothesis would be that it stays in place, with verb movement around it accounting for verb–subject word order. Several authors have provided evidence, however, that the subject has to move too. Hendrick (2000), for example (following McCloskey 1997), discusses adverb placement in Celtic languages as evidence of such movement, and CM shows similar data. Consider (49):

- (49) (a) čaà=rí šîã žáʔa
 come=1 tomorrow here
 ‘I’ll come here tomorrow’
- (b) ndukòò=ró žáʔa té ndeʔe=ró
 sit=2 here and watch=2
 ‘Sit here and watch [over him/her]’

Assuming that AdvPs must adjoin only to non-argumental XPs, the position of the subject to the left of the adverbs in the examples in (49) indicates that it has moved from its initial position within the VP (as schematized in (50)):

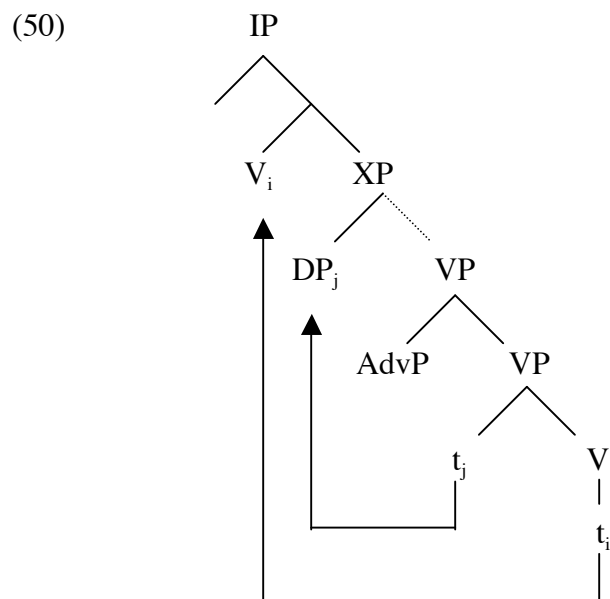

A second type of construction which suggests that the subject raises is a quantifier-float-like construction involving the plural word. The plural word is an interesting syncategorematic lexical item. First, note that the marking of plurality in CM is always optional—both on the verb and on the noun. While the optional marking on the verb is affixal (as shown in (51)), with

nouns plurality is marked by use of a free morpheme xináʔa, which simply means ‘plural’. This is illustrated in (52).

- (51) ká-žaà=to
 PL-reside=3POL.OLD
 ‘They live (there)’
- (52) (a) s-kitáʔă žŭnŭ žáʔa xínaʔa=Ø
 CAUS-meet wood this plural=3
 ‘Put these (pieces of) wood together’
- (b) kíʔĩ=ni xínaʔa=ni
 go=2POL plural=2POL
 ‘(You plural) go!’
- (c) táa=rí xínaʔa=Ø ni-ka-xaà íkú
 parent=1 plural=3 CP-PL-arrive.there yesterday
 ‘My parents arrived yesterday’

In (52a) ‘wood’ is pluralized (in a count sense) with xináʔa. (52b) shows that a pronominal clitic subject can also be pluralized with xináʔa. In (52c) the subject, including xináʔa, has been focused (and in this case cooccurs with the plural prefix ka- on the verb—although as noted above this is totally optional).

Space does not permit detailed discussion about the lexical category and constituency of xináʔa,¹⁴ which are interesting questions in their own right, but do note the agreement which appears on it—silently in (52a) and (c), but overtly in (52b). I take this to indicate that xináʔa is adjoined to the DP, rather than a part of the DP proper.

What is interesting about xináʔa for our purposes at this point is that it can be stranded. This is the only construction in CM in which discontinuous constituents are allowed. Consider (53):

- (53) xalúlí wá na-kée xínaʔa=Ø
 child that OPT-eat plural=3
 ‘The children should/must eat’

In (53), the subject DP has been focused without xináʔa. That is, fronting to focus position has stranded xináʔa in a position after the verb. But xináʔa can also be separated from the DP which it pluralizes in other ways, as illustrated in (54):

- (54) (a) kúžaa=ri núndua xínaʔa=ri
 live=1 Oaxaca plural=1
 ‘We will live in Oaxaca’

¹⁴ See Macaulay (1989, 1996) for details.

- (b) ñǎʔǎ=ní xǐí=ná xínáʔá=ní
 come=2POL with=1POL plural=2POL
 ‘(You plural) come with me’

In (54a) the clitic subject is separated from the plural word by a locative adjunct, and in (54b) it is separated from the plural word by an adjunct prepositional phrase. These examples are similar to (49a) and (b) in that they show the raising of the subject around an adjunct, but in these examples the plural word fails to pied-pipe, and remains in a lower position in the clause.

Returning to the issue of where the subject lands when it raises, recall that in addition to the word order verb–subject–adverb (as shown in (49)), we also find verb–adverb–subject in CM. We saw this with a pronominal clitic in (32b), and (55) shows that a full DP subject may likewise follow an adverb:

- (55) k^wa-k^waʔnu báʔa ítu wá
 go-grow well crops that
 ‘The crops are growing well’

This might be taken to indicate that the subject has the option of staying in its VP-internal position. Instead, I will adopt the approach of Benmamoun (1999), who argues that the postverbal subject in Arabic VSO clauses is in Spec of IP, meaning that the verb must be located in a position beyond IP. Benmamoun proposes this in order to argue that Case is checked only in a Spec-head configuration, rather than under government (as in earlier approaches). I will adopt his analysis simply as a convenient structure with which we can account for the facts of Mixtec word order, but leave aside the theoretical controversies involved.

Benmamoun, then, claims that the position above IP to which the verb raises is a focus projection, as shown in (56). The subject raises to Spec of IP for VSO order (as in (56a)), and to Spec of FP for SVO order (as in (56b)). (Note that I have omitted the object in these trees for clarity.)

(56) (a) VSO ORDER

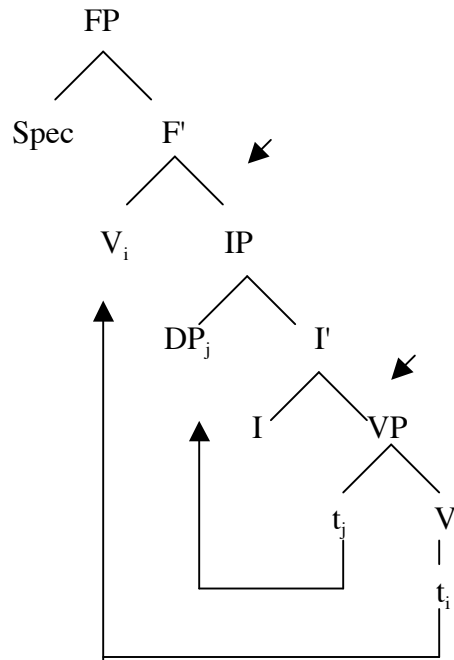

(b) SVO ORDER (FOCUS)

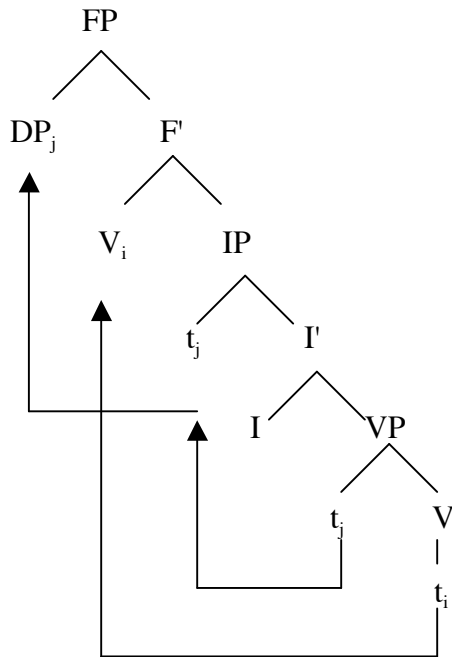

The two postverbal positions for adverbs are indicated by arrows in (56a). That is, for verb–adverb–subject order, the AdvP is adjoined to IP; for verb–subject–adverb order, the AdvP is adjoined to VP.

As a final point, recall the two rather strange sentences introduced earlier as (23a) and (b); repeated here as (57a) and (b):

(57) TWO PREVERBAL CONSTITUENTS

(a) *kaxá wáã tènana ñú?ũ=Ø*
caja the tomato contain=3
 ‘The box contains tomatoes’

(b) *burrú=ró wáã nužá?u xíndee=Ø*
burro=2 that plaza be.in=3
 ‘Your burro is in the plaza’

In each case the example shows a transitive verb with both of its arguments in preverbal position. Although this is highly marked, both of these sentences were produced spontaneously, and I do not believe that they were performance errors. What they show is that it is possible to have both topic and focus in the same sentence. It is unusual for both positions to be filled, but as these examples show, it can happen.

4. Conclusion

This paper has provided a general overview of Chalcatongo Mixtec syntax, with a focus on structures involving preverbal elements.

I have reviewed a number of the claimed correlates of VSO word order, showing that CM fits into the profile given by Greenberg fairly well (although, as noted, other dialects do have question particles in places that Greenberg would not have predicted). I also considered some of the more recent claims about correlates of VSO word order, and showed that CM splits on the predicted lack of a copula, in that it requires a copula for nominal predicates, but only optionally has one for adjectival predicates. Additionally, I noted that—contra the claims of Freeze and Georgopolous (2000)—CM does in fact have a lexical verb ‘have’.

The second part of the paper was dedicated to looking at evidence from the distribution of clitic, pronominal, and full lexical subjects, with an eye to what CM can contribute to ongoing discussions of the kinds of structures proposed for the derivation of VSO word order. It was shown that CM allows two kinds of preverbal element, a focus phrase and a topic. When the focus is subject, no clitic doubling occurs, but when the topic is subject it is always doubled by a pronominal clitic. This is accounted for by treating the focused element as moving to preverbal position, but the topic as base-generated. The location of adverbs in CM led me to adopt a structure parallel to Benmamoun’s approach to VSO word order in Arabic. This approach involves moving the verb past IP, into focus position, moving postverbal subjects into spec of IP, and moving focused phrases into spec of FP. This gives us two maximal projections to which

adverb phrases can be adjoined, VP (accounting for adverbs that appear to the right of a postverbal subject), and IP (accounting for adverbs that appear between the verb and the subject).

References

- Alexander, Ruth Mary. 1988. A Syntactic Sketch of Ocotepc Mixtec. In Bradley and Hollenbach (eds.), pp. 151-304.
- Alexopoulou, Theodora, Edit Doron, and Caroline Heycock. 2001. Broad Subjects and Clitic Left Dislocation. <http://www.ling.ed.ac.uk/~theodora/theorpapers.html>. (To appear in D. Adger (et al.) (eds.), *Left Peripheries*, Oxford University Press.)
- Benmamoun, Elabbas. 1999. Spec-Head Agreement and Overt Case in Arabic. In Adger, David, Susan Pintzuk, Bernadette Plunkett, George Tsoulas (eds.), *Specifiers: Minimalist Approaches*, pp. 110-125. Oxford: Oxford University Press.
- Black, Cheryl A. 2000. Quiégolani Zapotec Syntax: A Principles and Parameters Account. SIL International and University of Texas at Arlington.
- Bradley, C. Henry & Barbara E. Hollenbach (eds.). 1988. *Studies in the Syntax of Mixtecan Languages*, Vol 1. Summer Institute of Linguistics, publication no. 83.
- . 1990. *Studies in the Syntax of Mixtecan Languages*, Vol 2. Summer Institute of Linguistics, publication no. 90.
- . 1991. *Studies in the Syntax of Mixtecan Languages*, Vol 3. Summer Institute of Linguistics, publication no. 105.
- Carnie, Andrew Hay. 1995. *Non-Verbal Predication and Head-Movement*. Unpublished Ph.D. Dissertation, Massachusetts Institute of Technology.
- Carnie, Andrew and Eithne Guilfoyle (eds.). 2000. *The Syntax of Verb Initial Languages*. Oxford University Press.
- , Heidi Harley, and Elizabeth Pyatt. 2000. VSO Order as Raising out of IP? Some Evidence from Old Irish. In Carnie and Guilfoyle (eds.), pp. 39-59.
- Farris, Edwin R. 1992. A Syntactic Sketch of Yosondúa Mixtec. In Bradley & Hollenbach (eds.), pp. 1-171.
- Freeze, Ray. 1992. Existentials and Other Locatives. *Language* 68:553-595.
- and Carol Georgopoulos. 2000. Locus Operandi. In Carnie and Guilfoyle (eds.), pp. 163-183.

- Greenberg, Joseph H. 1963. Some Universals of Grammar with Particular Reference to the Order of Meaningful Elements. In Joseph H. Greenberg (ed.), *Universals of Language*, 2d ed., pp. 73–113. Cambridge, Massachusetts: MIT Press.
- Halpern, Aaron and Josep M. Fontana. 1994. X^0 and X^{max} Clitics. *WCCFL* 12:251-266.
- Hendrick, Randall. 2000. Celtic Initials. In Carnie and Guilfoyle (eds.), pp. 13-37.
- Hills, Robert A. 1990. A Syntactic Sketch of Ayutla Mixtec. In Bradley and Hollenbach (eds.), pp. 1-260.
- Johnson, Audrey F. 1988. A Syntactic Sketch of Jamiltepec Mixtec. In Bradley and Hollenbach (eds.), pp. 11-150.
- Kuiper, Albertha and Joy Oram. 1991. A Syntactic Sketch of Diuxi-Tilantongo Mixtec. In Bradley and Hollenbach (eds.), pp. 179-408.
- Lambrecht, Knud. 1994. *Information Structure and Sentence Form*. Cambridge University Press.
- Lee, Felicia. 2000. VP Remnant Movement and VSO in Quiavini Zapotec. In Carnie and Guilfoyle (eds.), pp. 143-162.
- Macaulay, Monica. 1989. The Plural Word in Chalcatongo Mixtec. In Proceedings of the 25th Annual Meeting of the Chicago Linguistic Society: 288–299.
- . 1996. *A Grammar of Chalcatongo Mixtec*. Berkeley: University of California Press.
- McCloskey, James. 1997. Subjecthood and Subject Positions. In Liliane Haegeman (ed.), *Elements of Grammar: Handbook in Generative Grammar*, pp. 197-236. Kluwer, Dordrecht.
- Myhill, John. 1985. Pragmatic and Categorical Correlates of VS Word Order. *Lingua* 66:177-200.
- Pike, Kenneth L. 1944. Analysis of a Mixteco Text. *IJAL* 10(4): 113-138.
- Salmons, Joseph. 1992. Root Oriented Phonological Change in Two Mixtec Dialects. (Ms.)
- Shields, Jäna K. 1988. A Syntactic Sketch of Silacayoapan Mixtec. In Bradley & Hollenbach (eds.), pp. 305-449.
- Small, Priscilla C. 1990. A Syntactic Sketch of Coatzospan Mixtec. In Bradley & Hollenbach (eds.), pp. 261-479.
- Suárez, Jorge A. 1983. *The Mesoamerican Indian Languages*. Cambridge University Press.

Zylstra, Carol F. 1991. A Syntactic Sketch of Alacatlazala Mixtec. In Bradley & Hollenbach (eds.), pp. 1-177.

Zwicky, Arnold. 1977. On Clitics. Ms.